

# ETEOS

• Order date

• Order number

• Serial ID

• Dealer

## Customer details

• Gender   Female   Male

• Last name  • First name

• Country  • City

• Address  • Postcode

• Phone  • E-mail

• Date of birth  • Weight  Kg • Height  cm

• Degree of disability

• Specific  
Characteristics



# ETEOS

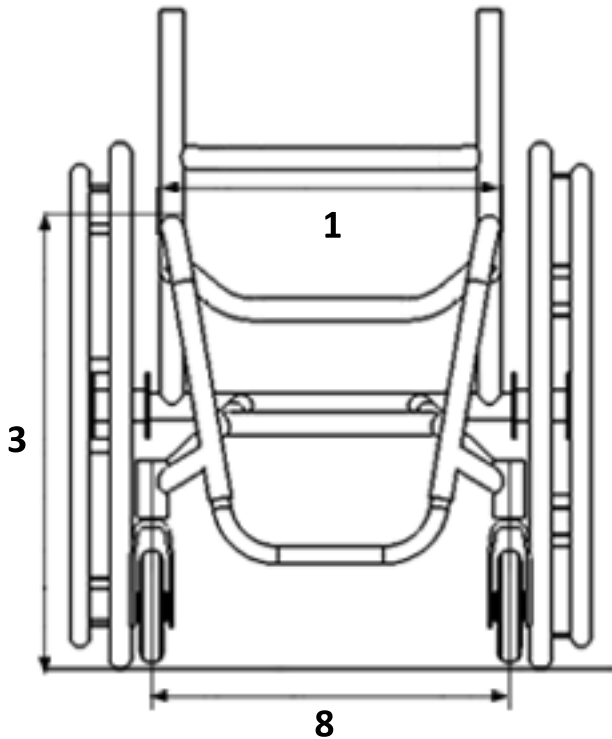
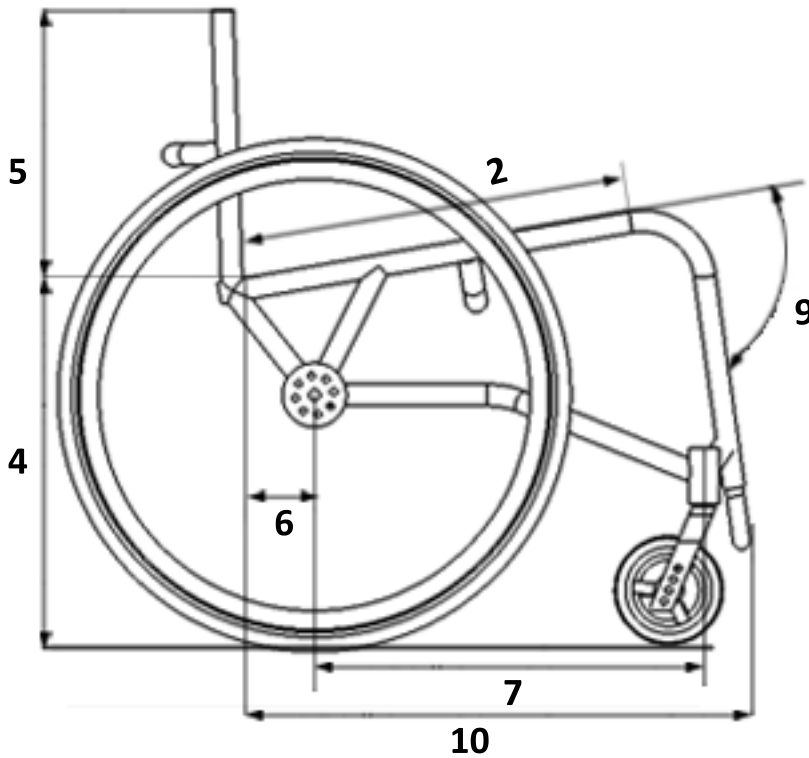

- 1. Seat width (mm) .....
- 2. Seat depth (mm) .....
- 3. Wheelchair front seat height (mm) .....
- 4. Wheelchair rear seat height (mm) .....
- 5. Backrest height (mm) .....
- 6. Axle position (mm) .....
- 7. Distance between axles (mm) .....
- 8. Distance between directional wheels (mm) .....
- 9. Angle between seat - footrest (°) .....
- 10. Wheelchair total length (mm) .....

• Backrest / Degrees (°) .....

Fixed  Reclining

• Drive wheels Camber (°) .....

• Front wheel diameter (mm)

Φ80     Φ100     Φ125     Φ150

• Rear wheel diameter (inch)

20"     22"     24"     26"

• Shoe width (mm) .....



• Distance between footplate - leg (mm) .....

